

# Indirect Method for Determination of Paracetamol in Pure and Pharmaceutical Drugs using CFIA with Homemade Ayah 3S<sub>BGR</sub>X3-3D Solar Cell Microphotometer Analyzer

Nagam S. Turkey Al-Awadie<sup>1</sup>, Marwah A. Kadhim Al-banaa<sup>2</sup>

<sup>1</sup>Department of Chemistry, College of Science, University of Baghdad, Baghdad, Iraq,

<sup>2</sup>Department of Optical Techniques, Dijlah University College, Baghdad, Iraq.

## Abstract

A method is described for the determination of paracetamol (based on the formation of an orange-reddish color species by reduction of Fe(III) to Fe(II) by paracetamol and then reacted with 1,10-phenanthroline) in the range 0.001-0.09 mMol.L<sup>-1</sup> ( $r=0.9801$ ,  $r^2=0.9606$ , and  $R^{2\%}=96.06$ ) with a detection limit (LOD) 21.77 ng/160  $\mu$ L (3SB) (S/N=3) and with RSD% for 0.01 and 0.07 mMol.L<sup>-1</sup> less than 1% (n=6). The method was applied successfully for determination of paracetamol in pharmaceuticals formulation. Analysis of drugs used the standard additions method via the individual t-test. The results showed a significant difference between the quoted value of each company with calculated t-test at 95% confidence ( $\alpha=0.05$ ) from new method.

**Key words:** spectrophotometer, flow injection analysis, paracetamol

## Introduction

Paracetamol (Acetaminophen, 4-Acetamidophenol, N-(4-hydroxyphenyl) acetamide), Tylenol), is now probably the most commonly used drug worldwide, available over the counter, used as an analgesic and antipyretic drug<sup>(1,2)</sup>. It is preferred alternative analgesic-antipyretic to aspirin, particular in patients that could not be treated with non-steroidal anti-inflammatory drugs, such as people with pregnant or breastfeeding women, children under 12 years of age, bronchial asthma, salicylate-sensitized people, peptic ulcer disease, hemophilia. It is available in uncontaminated type as various trade-name preparations for oral use and organized combined in over 200 preparations with further drugs<sup>(3)</sup>.

Some side effect may occur of paracetamol observed after higher doses (4g/24h), specially in the liver, so United States Food and Drug Administration (USFDA) produced it on the recorded elaborations, which will endure definite checking on the basis of data from the system on adverse reactions. The preparations containing paracetamol will be assessed in terms of introducing adverse skin reactions<sup>(4)</sup>.

Several methods for determination of paracetamol have been reported such as LC<sup>(5)</sup>, RP-HPLC<sup>(6)</sup>, spectrophotometry<sup>(7)</sup>, Chemiluminescence<sup>(8)</sup>, Electrochemical detection<sup>(9-13)</sup> and Merging zone-continuous flow injection technique<sup>(14)</sup>. In the present study, (Ayah 3S<sub>BGR</sub>X3-3D solar cell microphotometer analyzer<sup>(15)</sup> was used) as a sensitive and simple method for the determination of paracetamol via the recorded of the signal from the measurement of absorbance at 525 nm green light emitted diode (LED) as a source.

## Experimental

### Chemicals

The following stock solutions were prepared

- Paracetamol solution, 0.05 Mol.L<sup>-1</sup> (151.16g.Mol<sup>-1</sup>, BDH, UK). Dissolve 1.8895g of C<sub>8</sub>H<sub>9</sub>NO<sub>2</sub> in distilled water in a 250 mL volumetric flask.

- 1,10-phenanthroline, 0.1 Mol.L<sup>-1</sup> (180.2g.Mol<sup>-1</sup>, BDH, UK). Dissolve 9.01g of C<sub>12</sub>H<sub>8</sub>N<sub>2</sub> in distilled water in a 500 mL volumetric flask.

- Iron(III), 0.2 Mol.L<sup>-1</sup> (278.0146g.Mol<sup>-1</sup>

<sup>1</sup>,FLUKA,Germany). Dissolve a weight of 13.9007g  $\text{FeSO}_4 \cdot 7\text{H}_2\text{O}$  after that the addition of 2-3 drops of concentrated  $\text{H}_2\text{SO}_4$  after dissolution in little amounts of water (approximately 100mL followed by the addition of 80mL of  $\text{H}_2\text{O}_2$  0.1Mol.L<sup>-1</sup> which is prepared and purified through passing on a cation exchanger Amberlite 120) warming the solution with constant stirring for the completion of oxidation of Fe(II) into (III), continuation of doing so until bubbles ceases for removing the excess of  $\text{H}_2\text{O}_2$  followed by the addition 10-15mL of concentrated  $\text{H}_2\text{SO}_4$  (in order to avoid the turbidity of the solution, during the process of oxidation of Fe(II) to Fe(III)). The solution quantitatively transferred into a volumetric flask (250mL), the volume is completed with distilled water. <sup>(14)</sup>

### Apparatus

Ayah 3S<sub>BGR</sub>X3-3D solar cell microphotometer was used in this work as a homemade instrument<sup>(15)</sup> that measures the absorbance of any different sample segment color which is capable of absorption in the visible region of the spectrum by uses three sources of

irradiation : Blue (470nm), Green (525nm), and Red (635nm) with three solar cells as a detector at range of 450-1150nm. The instrument is composed of a block of brass having the dimensions of 20(width), 20(thickness) and 90mm(length). Flow cell with ID=2mm and OD=4mm that embedded inside a metal block. Nine source of light emitting diodes were used as an array arrangement act as emission sources at 100mm distance with three solar cell as a detector. The output of measure by solar cells was used without any further amplification of the transmitted light signal as shown in fig.1-A(X,Y-t potentiometric recorder,(Kompenso, Graph C-1032, Siemens, Germany, 1-500 volt, 1-500mV)).

Fig.1-B shows the manifold system that uses flow system represent by peristaltic pump (An ISMATEC, Switzerland, type ISM796 peristaltic pump, two channels), six ports rotary injection valve (Six ports medium pressure (model,V-450)(upchurch, scientific INC) valve (Teflon) was used with a variables sample volumes) and (Homemade Y liquid junction point. made of poly methylmethacrylate (PMMA)).

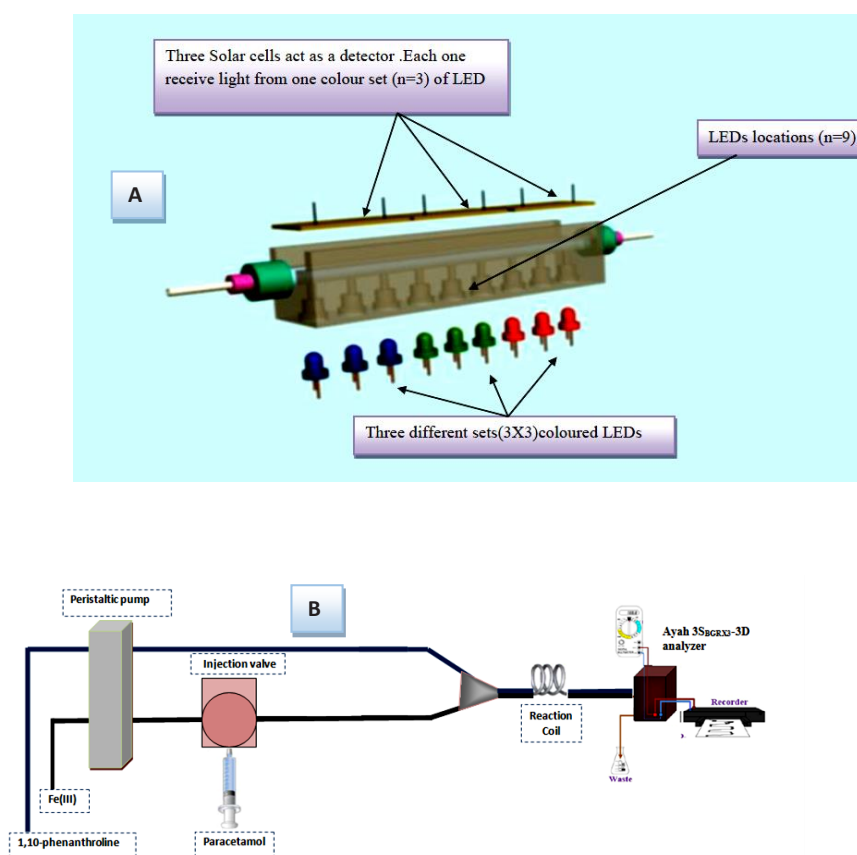

Figure 1:A- 3D-representation of the brass metal housing of the used LEDs, their location , flow cell, and the three solar cell ; each collect light from one set(single colour) of LEDs

**B- Schematic diagram of flow system for the determination of paracetamol**

**Methodology**

A manifold system used in this research consist of two line flow feed unit: first line supplies Fe(III) (0.03mMol.L<sup>-1</sup> with flow rate 2.4mL.min<sup>-1</sup>) which passes through injection valve carrying the paracetamol sample(0.03mMol.L<sup>-1</sup> with sample volume 160μL)

which lead to reduction of Fe(III) to Fe(II) then combined with the second line (1,10-phenanthroline, 0.3mMol.L<sup>-1</sup> with flow rate 2.5mL.min<sup>-1</sup>) at a liquid junction point (Y-junction) that will produce orange-reddish color which passes through delay reaction coil (32cm,0.25mL) to completed formation of colored species and then to Ayah 3S<sub>BGR</sub>X3-3D to measure absorption process at green light emitted diode(LED) as a source. A proposed mechanism for the reaction occurred in the manifold system expressed in sketch number 1.

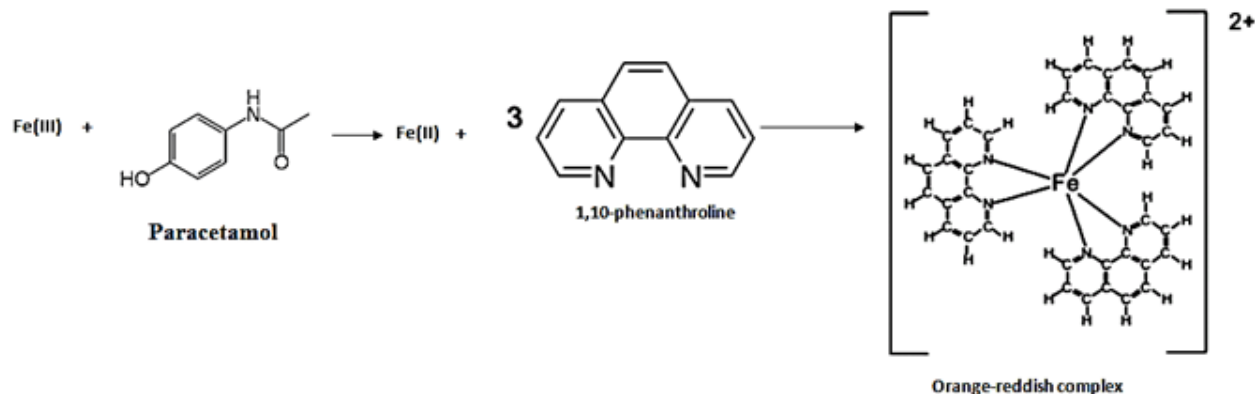

**Sketch number1: A proposed equation of reaction between Fe (III) and paracetamol with**

**1,10-phenanthroline**

**Results and Discussion**

**Chemical Variables**

A spectroscopic study for colored species (orange-reddish color) was monitoring by a homemade Ayah 3S<sub>BGR</sub>X3-3D solar cell CFIA microphotometer at three different super bright light diode (LED) as a source (blue 470nm, green 525 nm, and red 635 nm) using paracetamol(0.03mMol.L<sup>-1</sup>,130μL)- Fe(III)

(0.01mMol.L<sup>-1</sup>)- 1,10- phenanthroline (0.07mMol.L<sup>-1</sup>) system with flow rate at 2.3 and 2.4 mL.min<sup>-1</sup> of the line no.1 (carrier stream) and line no.2 (reagent stream) respectively. Fig.2 shows the maximum response measured in mV was obtained using green light emitting diode so it used for the determination of paracetamol in next studies.

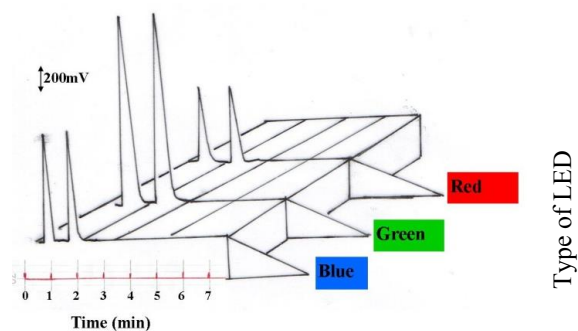

**Figure 2: Responses profile (mV) verses differences light emitting diode using Ayah 3S<sub>BGR</sub> x 3 -3D solar cell CFIA microphotometer for 0.03mMol.L<sup>-1</sup> paracetamol**

**Effect of Fe(III) concentration**

Fe(III) solutions of different concentrations were prepared (0.005-0.07mMol.L<sup>-1</sup>) using physical parameters : flow rate 2.3 and 2.4, mL.min<sup>-1</sup> for the Fe(III) stream and 1,10-phenanthroline(0.07mMol.L<sup>-1</sup>) stream respectively , sample volume 130μL(0.03mMol.L<sup>-1</sup> paracetamol) and open valve mode. The maximum response of the colored species obtained was noticed at 0.03mMol.L<sup>-1</sup> of Fe(III) concentration (more than 0.03mMol.L<sup>-1</sup> could due to restriction of the passage incident light due to. small. colored colloidal. precipitate

which be formed in front of solar cells.) So it was found that  $0.03\text{mMol.L}^{-1}$  of Fe(III) was the most suitable.

### Effect of 1,10-phenanthroline concentration

Solutions containing  $0.03\text{mMol.L}^{-1}$  Fe(III) and  $0.03\text{mMol.L}^{-1}$  paracetamol with different 1,10-phenanthroline concentrations ( $0.05\text{-}0.7\text{mMol.L}^{-1}$ ) were prepared. It was noticed at more than  $0.3\text{mMol.L}^{-1}$  a decrease in response which can be attributed to increase of the colored species density which work as, internal filter that really prevent the remaining. light intensity, after absorption. process. so it was chosen  $0.3\text{mMol.L}^{-1}$  of 1,10-phenanthroline concentration for optimum sensitivity and reproducibility response.

### Physical variables

#### Flow Rate

Using chemical variation for : paracetamol ( $0.03\text{mMol.L}^{-1}$ )- Fe(III) ( $0.03\text{mMol.L}^{-1}$ )- 1,10-phenanthroline ( $0.3\text{mMol.L}^{-1}$ ) system and physical parameters including : sample volume ( $130\mu\text{L}$ ) and open valve mode with variation of flow rates ( $1.9\text{-}2.7$ ), ( $1.9\text{-}2.7$ )  $\text{mL.min}^{-1}$  for Fe(III) line and 1,10-phenanthroline line respectively. A flow rate of 2.4 and 2.5  $\text{mL.min}^{-1}$  for Fe(III) and 1,10-phenanthroline line respectively was chosen as better flow rate because it was noticed at flow, rate ranged  $1.9\text{-}2.1\text{mL.min}^{-1}$  there is an increase in area of colored segment in front of detector (increase in  $\Delta t_B$  (base width) versus peak height and dilution factor) while at higher flow rate ( $>2.4$  and  $2.5\text{mL.min}^{-1}$  for Fe(III) and 1,10-phenanthroline stream respectively) the response is not very high because departure of reactant from measuring cell before to completion of reduction Fe(III) to Fe(II) (decrease time in front of detector and  $\Delta t_B$ ).

#### Sample Volume

Different sample volume ( $50\text{-}200\mu\text{L}$ ) with fixing all previous experimental parameters (chemical and physical parameters) with  $525\text{nm}$  as a source for irradiation were used. The results shows that increase in sample loop, led to an increase in S/N and  $\Delta t_B$  (base width) up to  $160\mu\text{L}$  (above  $160\mu\text{L}$ , there were a broadening at the peak height and  $\Delta t_B$ ) so as a comparison between  $\Delta t_B$ , peak

height and sensitivity,  $160\mu\text{L}$  could be used as best sample volume for the determination of paracetamol in next studies.

#### Purge Time

The purge time (time for purging of the paracetamol segment from the six port injection valve) was carried out in this work ( $5\text{-}30\text{sec}$ ). It was noticed from results obtained that open valve mode at  $30\text{sec}$  was chosen as most suitable purge time for the totally departure of colored species from the injection valve to obtain better response for determination of paracetamol.

#### Effect of reaction coil length

Variation coil length ( $0\text{-}57\text{cm}$ ) was used for the study of effect the reaction delay coil (after Y-junction point) on S/N peak profile,  $\Delta t_B$  and concentration of paracetamol after dilution. It was noticed that best coil length for the homogenization and completion of the reduction Fe(III) to Fe(II) with suitable base width ( $\Delta t_B$ ), decrease dilution effect and regular response was  $32\text{cm}$  ( $0.25\text{mL}$ ).

#### Preparation of calibration graph

Various concentrations ( $0.001\text{-}0.09\text{mMol.L}^{-1}$ ) of paracetamol was prepared using the parameters achieved above. Each measurement was repeated three times. Regression analysis gave  $r$  (correlation coefficient)  $0.9801$ ,  $r^2$  (coefficient of determination)  $0.9606$ , and  $R^2\%$  (linearity percentage)  $96.06$  as tabulated in table 1.

#### Limit of detection and repeatability

Gradual dilution of low concentration in the calibration graph and depend on the linear equation (numeric value of slope) was used for the calculated of detection limit. The repeatability studied for using Ayah 3S<sub>BGR</sub>X3-3D analyser by paracetamol-Fe(III)- 1,10-phenanthroline system at concentration  $0.01$  and  $0.07\text{mMol.L}^{-1}$ . All calculated obtained was tabulated in table 1.

**Table 1: Summary of calibration graph, detection limit and repeatability results for the determination of paracetamol using Ayah 3S<sub>BGR</sub>X3-3D solar cell CFI analyser**

Linear range of [paracetamol] mMol.L <sup>-1</sup> (n=10 )	$\hat{Y}_{(mV)} = a \pm s_a t + b \pm s_b t [X]$ mMol.L <sup>-1</sup> at confidence level 95%, n-2	r r <sup>2</sup> R <sup>2</sup> %	t- value at 95%, n-2		Detection limit	Repeatability at 95% confidence level, n-1		
			t <sub>tab</sub>	t <sub>cal</sub>		Theoretical based on slope	[paracetamol] mmol/L	$\bar{y}_i \pm 0.025, n-1 \sigma_{n-1} / \sqrt{n}$
0.001-0.09		0.9801 0.9606 96.06	2.306 << 13.96		(9x10 <sup>-</sup> )	5.19 µg/160µL	0.01	0.28
							0.01	

**Application**

Ayah 3S<sub>BGR</sub>X3-3D solar cell CFI analyser was used for the analysis of paracetamol using paracetamol- Fe(III)-1,10-phenanthroline system in the different drug manufactures (SDI-Iraq, Advance- United Kingdom, and Kernadol, Kern pharma-Espain) . A series of solutions were prepared of each paracetamol drug(20mMol.L<sup>-1</sup>) (0.3023g ) by transferring 0.01mL to each 10mL volumetric flask , followed by the addition of step wise volumes (0.0 ,0.01 ,0.02 ,0.03 ,0.04 mL from 10mMol.L<sup>-1</sup> standard solution) to obtain 0.0- 0.04 mMol.L<sup>-1</sup> . Table 2 shows all results obtained of standard calibration graph, practical content of paracetamol in each sample of drug and efficiency of determination using developed method at confidence level 95%.

**Table 2: Summed up of standard addition results , practical found values and ,efficiency determination**

Sample No.	Commercial name content and company country	95% onfidence interval for the average weight $W_i \pm 1.96 \sigma_{n-1} / \sqrt{n}$ (g)	Sample weight equivalent to 0.3023g (0.02 Mol.L <sup>-1</sup> ) of the active ingredient (g)	Theoretical content of the active ingredient at 95% (mg)	Equation of standard addition at 95% for n-2 $\hat{Y}_{(mV)} = a \pm s_a t + b \pm s_b t$ r,r <sup>2</sup> ,R <sup>2</sup> o%	Practical content $W_i \pm 4.303 \sigma_{n-1} / \sqrt{n}$ (mg) for (n=3) ,at 95% W <sub>i</sub> (g)	Efficiency of determination (Rec. %)
1	SDI-Iraq	0.1213±0.0058	0.0733	500±23.91	501.8±52.22+23300±2132.02 [paracetamol]mMol.L <sup>-1</sup> 0.9988,0.9975,99.75 %	537.66±3.45 0.3249	107.5
2	Advance United Kingdom	0.1482±0.0532	0.0896	500±179.5	328.0±140.80+17100±5748.19 [paracetamol]mMol.L <sup>-1</sup> 0.9837,0.9676,96.76%	479.99±2.82 0.2902	95.9
3	Kernadol, Kern pharma Spain	<b>0.1023±0.0495</b>	0.0619	500±241.94	668±103.00+31600±4205.39 [paracetamol] mMol.L <sup>-1</sup> 0.9974,0.9948,99.48%	527.04±3.54 0.3189	105.4

The standard addition method in this research work was put into individual t-test between  $\bar{x}$  (mean) and quoted value, (500mg). There is a significant difference between claimed value of each company with t calculated at  $\alpha=0.05$  (95% confidence interval).

### Conclusion

The method in this research work described for the determination of paracetamol by reduction of Fe(III) to Fe(II) and then combination with 1,10-phenanthroline to form orange-reddish colored species. Homemade Ayah 3S<sub>BGR</sub>X3-3D solar cell CFI analyser was used for the measurement of absorbance at 525nm green light emitted diode (LED) as a source. The new technique was applied successfully for the determination of sample (paracetamol) in three different drugs.

**Acknowledgement:** I would like to express my deepest gratitude to Prof. Dr. Issam M.A. Shakir Al-Hashimi for his appreciable advice, important comments, support and encouragement.

**Ethical Clearance:** The Research Ethical Committee at scientific research by ethical approval of both environmental and health and higher education and scientific research ministries in Iraq

**Conflict of Interest:** The authors declare that they have no conflict of interest.

**Funding:** Self-funding

### References

- 1) Mattia C, Coluzz F. What anesthesiologists should know about paracetamol (acetaminophen). *Minerva Anesthesiol.* 2009 Nov ;75(11):644-53.
- 2) Jonathan J, Peter F, Sumit S. Intravenous acetaminophen: a review of pharmacoeconomic science for perioperative use. *Am J Ther.* 2013 Mar;20(2):189-99.
- 3) David FT. Analytical profiles of drugs substances. *Microchem J.* 1973 Aug;18(4):447-446.
- 4) Marta JB, Jerzy ZN. Paracetamol : mechanism of action, application and safety concern. *Acta Polonia Pharmaceutica.* 2013 Nov;71(1):23-11.
- 5) Qin-you T, Rong-hua Z, Huan-de L, Feng W, Miao Y, Li-bo D. Simultaneous quantitative determination of paracetamol and its glucuronide conjugate in human plasma and urine by liquid chromatography coupled to electrospray tandem mass spectrometry: Application to a clinical pharmacokinetic study. *Chromatogr B.* 2012 Apr;893-894(15):167-162.
- 6) Eglal AA, Ibrahim AN, Eman SH, Nouruddin W. HPLC and RP-HPLC methods for simultaneous determination of paracetamol and pamabrom in presence of their potential impurities. *J Pharm Biomed Anal.* 2015 Oct;114(10):27-22.
- 7) Siniša G, Marija G, Vladislav T. Simultaneous quantitative determination of paracetamol and tramadol in tablet formulation using UV spectrophotometry and chemometric methods. *Spectrochim Acta A Mol Bimol Spectrosc.* 2016 Mar; 157(15):264-258.
- 8) Mortaza I, Sakineh K, Masoud S. Chemiluminescence reaction of graphene oxide-luminol-dissolved oxygen and its application for determination of isoniazid and paracetamol. *Microchem J.* 2019 May ; 146:855-850.
- 9) Tanuja SB, Kumara BE, Vasantakumar P. Electrochemical determination of paracetamol in presence of folic acid at nevirapine modified carbon paste electrode : A cycle voltammetric study. *J Electroanal Chem.* 2107 Aug; 798(1):23-17.
- 10) Ademar W, Anderson MS, Orlando FF. Simultaneous determination of paracetamol and levofloxacin using a glassy carbon electrode modified with carbon black, silver nanoparticles and PEDOT:PSS film. *Sens Actuators B Chem.* 2018 Feb;255(2):2273-2264.
- 11) Sudip B, Dipanjan C, Rashmita D, Rajib B, Panchanan P. A simple synthesis of nitrogen doped porous graphitic carbon: Electrochemical determination of paracetamol in presence of ascorbic acid and p-aminophenol. *Anal Chim Acta.* 2015 Aug ;890(26):107-98.
- 12) Pramod KK, Ashwini KS. Simultaneous voltammetric determination of paracetamol, cetirizine and phenylephrine using a multiwalled carbon nanotube-platinum nanoparticles nanocomposite modified carbon paste electrode . *Sens Actuators B Chem.* 2016 Oct ; 233(5):248-237.
- 13) Anderson MS, Fernando CV, Luiz CS, Patricia BD, Orlando FF. Flow injection simultaneous determination of acetaminophen and tramadol in pharmaceutical and biological samples using multiple pulse amperometric detection with a boron-doped diamond electrode. *Diam Relat*

Mater. 2015 Nov; 60:8-1.

- 14) Issam MA, Nagham ST, Mohammed JA. New approach for the online determination of paracetamol using merging zone-continuous flow injection analysis via home made photometric based on 704nm LED and a photo silicon minidetector(NCJ). *Irq Nat J Chem.*2010 Jan ;39(39):455-468.
- 15) Issam M A S & Nagam S T., 2012. Ayah 3SX3-3D-Solar Analyser , Patent ,G01N29/00.