

Study the Genotoxicity of Aqueous and Alcoholic Extracts of *Adhatoda Vasica* on the Roots of *Allium cepa* L. by RAPD-PCR Technique

Adnan Owayez Jasim¹, Mohammed Mahdi Jawad¹

¹Iraq/University of Baghdad – College of Education /Ibn-Al-Haitham-Biology dept.

Abstract

The Molecular technique RAPD-PCR used to detect the genotoxicity of different concentrations of aqueous and alcoholic extracts of *Adhatoda vasica* leaves on onion *Allium cepa* L. roots. Five concentrations (1%, 2%, 3%, 5%, and 7.5%) and (10%, 15%, 20%, 30% and 40%) were adopted for alcoholic and aqueous extracts respectively. Ten arbitrary primers used in this study, only eight showed polymorphic bands in the gel and two primers were neglected because they did not show any polymorphic bands for all samples. The aim of this study is to detect the toxic effect of the extracts on the root of onion. The emergence and disappearance of bundles in the genome of onion plant *Allium cepa* L. Treatment with extracts was studied. The genetic relationship tree was established and the genetic distance calculated based on the results obtained from the gel electrophoresis to clarify the toxic effects of the extracts. The results showed that the concentrations that gave the highest effect and the most toxic for aqueous extract is 40% and for the alcoholic extract is 7.5% which are recommended as effective concentrates if used as a pesticide.

Key words: RAPD, *Adhatoda vasica*, Extracts, genotoxicity, *Allium cepa* L.

Introduction

Acanthaceae a family that composed of many well-known medicinal plants comprises approximately of 3,400 species and 364 genera. The name *Adhatoda vasica* Nees, whose synonym is *Justucia adhatoda* L.⁽¹⁾ was selected for experiments on its extracts in this study. *A. vasica* is an evergreen plant. It grows in the form of herbaceous trees distributed all over the world and in various environmental conditions, it lives at an altitude of 1300 m above sea level in the Indian Himalayas^(2,3).

A. vasica leaves contain a number of chemicals such as alkaloids, flavonoids, turbinones, and saponins⁽⁴⁾. Alkaloids as Vasicinone. Vasicinol. Adhatodin. Adhatonine. Antisotone and peganine⁽⁵⁾. The leaves contain two major alkaloids vasicine and vasicinone⁽⁶⁾. Vasicine alkaloid is one of the most effective substances that can be obtained from the leaves of the plant of the seven throat and by 95% of the isolated alkaloids⁽⁷⁾. The leaves and flowers of *A. vasica* are used as a medicine because they possess many chemical components such as carbohydrates, protein, phenols as well as flavanoids and alkaloids⁽⁸⁾. *A. vasica* contains saponins and tannins

too⁽⁹⁾, and the roots contain many alkaloids as vasicol, vasicinolone, vasicinone, adhatonine, vasicine and vasicinol⁽¹⁰⁾. Medicinal herbs are a very important source of medicine throughout human history. *A. vasica* is a plant known in ancient Greek medicine as a medicinal plant and used in the medical system for more than 2000 years⁽¹¹⁾, and it is widely used today, indicating that herbs are an increasingly important part of modern medicine. About 25 - 30 percent of the prescribed drugs today contain chemicals derived from plants⁽¹²⁾. *A. vasica*, with its various parts of high potential plants, is used for the development of the pharmaceutical and drug industries⁽¹³⁾. The plant was used as an anti-asthma and bronchodilator and in the treatment of wounds, ulcers, allergies and pulmonary tuberculosis. Genotoxicity is the sum of DNA damage that causes mutations. When medicinal plants are used to treat diseases, genetic toxicity must be detected. Genotoxicity of *A. vasica* plant extracts. In this study, genotoxicity was detected using the DNA of the onion *Allium cepa* L. roots as a biomarker to confirm the genotoxicity of *A. vasica* extracts.

Materials and Method

Plant sampling

A. vasica leaves were collected during the month of September 2018 from the gardens of the University of Baghdad / Baghdad-Iraq, leaf lengths were 12-27 cm and classified by the herbarium of the college of agriculture - University of Baghdad.

Preparation of extracts

Aqueous extract prepared from 25 g of *A. vasica* leaf powder added to 125 mL of distilled water (in boiling degree) so that the solution is easy to filtrate. Then put the solution on the hotplate stirrer for two hours and filter the solution through 4 pieces of gauze, and centrifuged at 3000 rpm. Place the filtrate in Petri dishes and enter the oven at 40 ° C. Scrape the extracted leaves after drying and store at room temperature until use ⁽¹⁴⁾.

To prepare the alcoholic extract, 125 ml of ethyl alcohol at 70% concentration added to 25 grams of dry powdered leaves and transfer the solution in a 50 °C for 24 hours in the shaking water bath. The steps were followed as in the preparation of aqueous extract ⁽¹⁵⁾.

Selection of samples and concentrations of extracts

Onions were selected in medium sizes (1.5, 2.2 cm) and 30 g weight, growing well at root lengths (2.5, 3.5 cm) the old roots were removed with dissecting blade and then the onion bulbs transferred to appropriate sized test tubes containing distilled water for 24 hours, then transferred to bottles containing a series of needed concentrations of alcoholic and aqueous extract of *A. vasica* leaves, adopted five concentrations (1%, 2%, 3%, 5%, 7.5%) and (10%, 15%, 20%, 30%, 40%), for alcoholic and aqueous extracts respectively, the onion bulbs still in their concentrations each for 7 days with considering the change of each solution every 24 hours to avoid increasing of concentration by water evaporation. After expiry of the exposure period, roots removed for further studies ⁽¹⁶⁾.

DNA extraction

DNA was extracted from onion roots that grown in each concentration solution studied by CTAB (Cetyl Trimethyl Ammonium Bromide) method ^(17, 18, 19) following the steps recommended by researchers in those references with some modifications.

Measuring the concentration and purity of DNA

The purity and concentration of DNA were measured using the Nano drop spectrophotometer by placing 2µL of each sample in a designated place of the device. The results appeared in private computer software. The DNA purity ranged from (1.7, 1.9) with different DNA concentrations measured in ng/ µl. The quality of the extracted DNA was determined by electrophoresed the samples onto 1% agarose gel .

PCR-RAPD technique

Primers used in RAPD-PCR reaction shown in Table (1) arbitrary primers supplied by Intergrati DNA Technology (IDT,USA). and Polymerase chain reaction PCR program shown in Table (2):

Table (1) Primers used in this study

No.	Primer	Primer sequence
1	OPA-1	5'-CAGGCCCTTC-3'
2	OPA-2	5'-TGCCGAGCTG-3'
3	OPA-3	5'-AGTCAGCCAC-3'
4	OPA-4	5'-AATCGGCGTC-3'
5	OPA-5	5'-AGGGGTCTTG-3'
6	OPA-6	5'-GCTCCCTGAC-3'
7	OPA-7	5'-GAAACGGGTG-3'
8	OPA-8	5'-GTGACGTAGG-3'
9	OPA-9	5'-GGGTAACGCC-3'
10	OPA10	5'-GTGATCGCAG-3'

Table (2): PCR program

Cycles No.	Temp. C°	Time	Steps
1	95	4min.	Initial denatur-ation
40	94	30sec.	Denaturation
	32-40	1min.	Annealing
	72	1min.	Extension
1	72	10	Final extension

Results and Discussion

RAPD –PCR technique

RAPD-PCR technique can be used effectively to detect DNA damage, therefore be used in genotoxicity studies (21, 22). It can be used without prior knowledge about the genome(23). It uses random primers with DNA template sequences (24). It has the ability to detect DNA damage and verify mutations in the DNA when toxic substances are used (25). Using RAPD-PCR technique in this study revealed the genotoxicity of *A. vasica* leaf extracts as shown in Figure 1. The emergence or acquisition of bands in gel electrophoresis occurred as a result of changes in the structure of the DNA (fracture, transfers or deletions). As for the deletion or loss of bands, it was due to the reduction of the number of areas of binding with the polymerase (25) or mutation or damage at the site of primer binding to the DNA strand, as well as that loss is as a result of DNA damage, point mutation, chromosomal rearrangement, deletion and addition to the sequences of nitrogenous bases in the DNA strands due to genotoxicity effect (26). The primers OPA3, OPA7 were neglected because they did not show any polymorphism in gel bands for all samples.

M–Molecular marker, C-control, 1-1% alcohol, 2-2% alcohol, 3-3% alcohol, 4-5% alcohol, 5-7.5 % alcohol, 6-10% aqueous, 7-15% aqueous, 8-20% aqueous, 9-30% aqueous, 10-40% aqueous.

After determining the purity and concentration of the extracted DNA of the extracts exposed roots, a high concentration of 800 ng/μl was found. Concentrations were reduced to 150 ng/μl for each extract. The results of the RAPD technique showed a variation in the PCR results of samples that exposed to aqueous and alcoholic extracts compared with the control treatment. Table 3 and 4 and Figure 1, show the RAPD-PCR results. It is clear from the results that the eight primers used gave fifty-five bands in control treatment and the molecular weights were between (140- 2109). As for the number of lost and gained bands, it was found that the alcoholic extract was more toxic to the onion roots genome than the aqueous extract.

Table (3) Lost and gained gel bands after PCR in roots of onion plant treated with aqueous extract concentrations.

Primer	Bands control	Band case	10%	15%	20%	30%	40%
OPA-1	7	Gain	5	5	3	3	2
		Loss	5	6	4	4	3
OPA-2	11	Gain	3	3	1	2	4
		Loss	6	8	6	6	7
OPA-4	6	Gain	2	-	2	1	3
		Loss	4	2	4	4	2
OPA-5	6	Gain	4	4	3	1	-
		Loss	3	3	2	1	2
OPA-6	6	Gain	-	-	-	-	-
		Loss	1	3	1	-	1
OPA-8	7	Gain	2	1	4	3	3
		Loss	3	1	2	4	5
OPA-9	4	Gain	4	5	4	2	1
		Loss	3	2	2	1	-
OPA-10	8	Gain	3	4	2	2	2
		Loss	5	5	5	3	3
Total	55	-	53	52	45	37	38

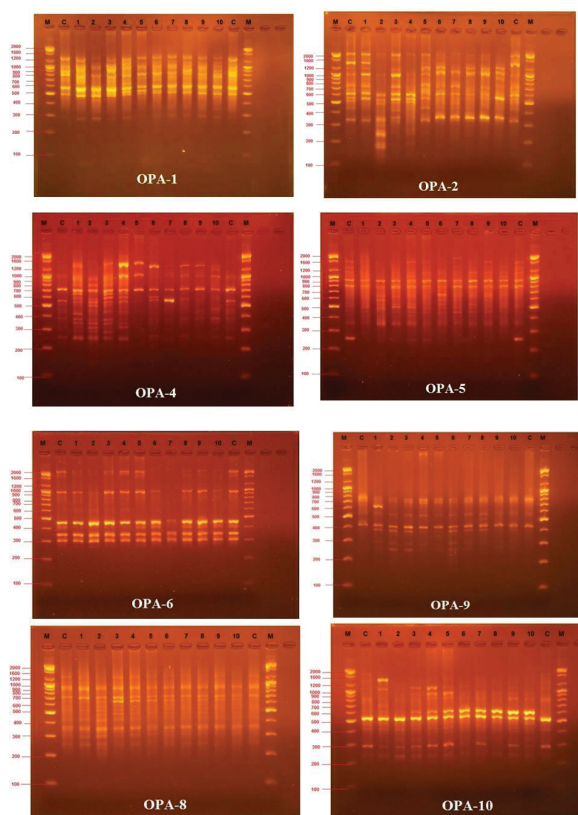

Figure (1) 2% agarose gel electrophoresis of onion roots treated with aqueous and alcoholic extracts of *A. vasica* leaves with molecular marker 100 to 2000bp (from Bioneer / Korea),

Table (4) Lost and gained gel bands after PCR in roots of onion plant treated with alcoholic extract concentrations.

Primer	Bands control	Band case	1%	2%	3%	5%	7.5%
OPA-1	7	Gain	4	2	3	3	3
		Loss	4	5	3	2	3
OPA-2	11	Gain	1	5	4	2	1
		Loss	2	7	6	7	4
OPA-4	6	Gain	11	7	10	11	2
		Loss	2	1	1	1	4
OPA-5	6	Gain	3	4	3	3	3
		Loss	3	3	2	1	1
OPA-6	6	Gain	-	-	-	-	-
		Loss	2	3	1	1	-
OPA-8	7	Gain	4	6	6	4	2
		Loss	3	3	3	2	2
OPA-9	4	Gain	5	4	6	4	2
		Loss	1	2	3	3	4
FOPA-10	8	Gain	4	2	3	3	4
		Loss	4	5	3	3	4
Total	55	-	53	59	57	50	39

The present study has shown a decrease in viability to death of the roots of *Allium cepa* when treated with different concentrations of both extracts, suggesting that it can be used as a pesticide to weed. Our findings evoke that Low concentrations were cytotoxic to onion roots while high concentrations of 40% and 7.5% of aqueous and alcoholic extracts respectively were prevented cell entry into mitosis. So it was more harmful to the food chain receptors. Consequently, the plant is unable to absorb it for this reason it is recommended to use low concentrations of both extracts as a pesticide⁽²⁷⁾.

Cluster analysis

UPGMA analysis was used to map the genetic relationship tree^(28,29,30) using Jaccard's similarity coefficients the tree results showed groups below(Figure 2).

Group A contains two groups, A1 group included control sample and onion sample exposed to alcoholic extract at 7.5% control (distilled water) and aqueous extract concentrations 20%, 30%, 40%. Group A2 included onion samples exposed to the aqueous extract concentrations of 10% and 15%.

Group B comprised two groups. Group B1 onion samples exposed to the concentration of alcoholic extract 1%, 2%. Either group B2 included samples exposed to alcoholic extract concentrate 3%, 5%.

The results of the genetic relationship tree showed the isolation of the results of aqueous extract from the alcoholic extract, and the isolation of the results of the exposure to control sample and the alcohol concentration of 7.5% were observed clearly.

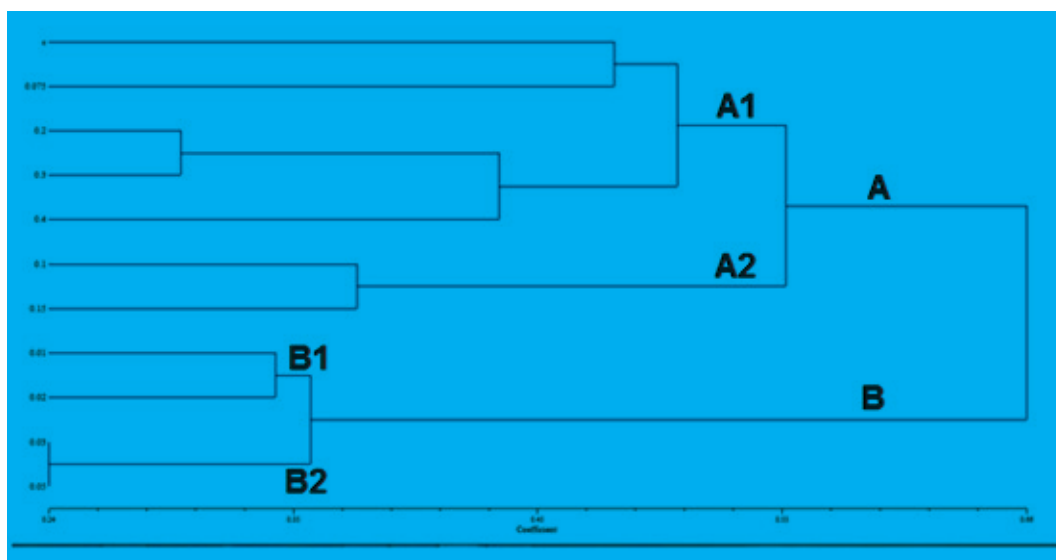

Figure 2: Genetic relationship tree of onion roots treated for aqueous and alcoholic extract concentrations of leaves *A. vasica*.

The tree showed the isolation of the control sample and the concentration of 7.5% alcohol compared to other samples treated with the extract (aqueous and alcoholic). This indicates that all the concentrations had an effect on the onion genome.

Conclusions

This study revealed that the concentration that gave the highest effect and the most toxic for aqueous extract is 40% and for the alcoholic extract is 7.5% because with these concentrations the plant cells started to die.

Ethical Clearance: The Research Ethical Committee at scientific research by ethical approval of both environmental and health and higher education and scientific research ministries in Iraq

Conflict of Interest: The authors declare that they have no conflict of interest.

Funding: Self-funding

References

- Sharma A, Sharma A, Kumar VR, Kumar A. Selected medicinal used in traditional medicine. *AJPHR*. 2015; 3: 30-38.
- Singhi SK, Patel DJR, Dangi A, Bachle D, Kataria RK. A complete over review on *Adhatoda vasica* a traditional medicinal plant. *Plants J*. 2016; 5(1): 175 – 180.
- Chaudhary E, Chauhan R, Chauhan N. Assessment of Bactericidal and Phytochemical Properties of *Adhatoda vasica* various Extracts against Gram Positive and Gram Negative Bacteria. *Int J Curr Microbiol App Sci*. 2017; 6 (7): 2660-2669.
- Yusuf M, Khan SA. *Adhatoda vasica* N. leaves extract: phytochemical analysis and antibacterial activity. *IJEAS*. 2016; 2: 26-32.
- Claeson UP, Malmfors T, Wikman G, Bruhn JG. *Adhatoda vasica*: a critical review of ethnopharmacological and Toxicological data . *J Ethnopharmacol*. 2000; 72: 1-20.
- Kumar KP, Bhowmik D, Tiwari, P, Kharel R. Indian tradition herbs *Adhatoda vasica* and its Medicinal application. *J Chem Pharm Res*. 2010; 2 (1): 240-245.
- Keesara BR, Jat RK. Isolation and characterization of Vasicine *Adhatoda vasica* (Ausa). *Int J Res Dev Pharm L Sci*. 2017; 6(2): 2590-2596.
- Chaun, WS, Sarangthem K. Phytochemical Constituents of *Justicia Adhatoda* Linn. found in Manipur. *JPS*. 2014; 3(2): 19- 21.
- Reddy MP, Shantha IR, Rao VR, Venkateshwarlu. Pharmacognostical and Physicochemical Evaluation on The flowers of *Juaticia adhatoda* L. *RJRP*. 2015; 7 (2): 73-90.
- Jain MP, Sharma VK. Phytochemical Investigation of Root of *Ahatoda vasica*. *JMPR*. 1982; 46 (12): 250 – 255.
- Sharma A, Kumar A. Acanthace: taxonomy and uses in traditional medicinal system. *Word J Pharm Res*. 2016; 5:403-412.

12. Prasad R, Lawania, RD, Manvi, Gupta R. Role of Herbs in the Management of Asthma. *Pharmacogn Rev.* 2009; 3 (4): 247-258.
13. Gangwar AK, Ghosh A. Medicinal uses Pharmacological activity of *Adhatoda vasica*. *Inet. J Herb Med.* 2014; 2(1): 88-91.
14. Müller J, Helndl A. Drying of Medicinal plants. In: Bogers, R. J; Craker, L. E. and Longe, D. (eds). *Medicinal and Aromatic plants*. Printed in the Netherland. 2006; 237-252.
15. Al-Obaidy SSM. The Effect of some crude Plant Extracts on the cell Division. M.Sc. thesis. The Collage of Science for Woman University of Baghdad. 2004; 146 pp.
16. Olorunfemi DL, Okieimen EA, Ovwemuvwose I. DNA integrity of onion (*Allium cepa* L) root cells exposed to ballast water. *studia Unvi. VG, SSV.* 2014; 24: 305-309.
17. Doyle JJ, Doyle JL. A rapid DNA isolation for small Quantities of fresh tissue. *Phytochem. Bull.* 1987; 19: 11-15.
18. Doyle JJ, Dickson. Preservation of plant sample for DNA endonuclease analysis. *Taxon.* 1987; 36: 715-722.
19. Cullings KW. Design and testing of a plant-specific PCR Primer for ecological and evolutionary studies. *Mol Ecol.* 1992; 1: 233-240.
20. Stainslav B, Om PR. Protocol: A high-throughput DNA extraction system suitable for conifers. *Plant Methods.* 2008; 2 (20): 1-6.
21. Atienzar FA, Jha AN. The random amplified polymorphic DNA (RAPD) assay and related techniques applied to genotoxicity and carcinogenesis studies: A critical review. *Mut Res.* 2006; 613: 67-102.
22. Hassan GH, Yassein AA. Cytogenotoxicity evaluation of water Contamination with some textile azo dyes using RAPD marker and Chromosome aberration of onion (*Allium cepa*) root cell. *Egypt J Genr Cyto.* 2014; 43: 39-57.
23. Babu KN, Rajesh MK, Samaudeen K, Minoo D, Suraby EJ, Anupama K, Ritto P. Randomly amplified polymorphic (DNA) RAPD and derived techniques. *Methods mol. Biol.*, 2014; 1115: 191-209.
24. Makino S, Okada Y, Maruyama T, Kaneko S., Sasakawa C. PCR-based random amplified polymorphic DNA Fingerprinting of *Yersinia Pseudotuberculosis* and its practical applications. *JCM.* 1994; 32(1): 65-69.
25. Danylchenko O, Sorochinsky B. Use of RAPD assay for the detection of mutation changes in plant DNA induced by UV-B and X-rays. *BMC plant Biol.* 2005; 5: 1-2.
26. Yunus MY, Aziz MA; Kadir MA; Daud SK, Rashid. *In vitro* mutagenesis of *Etilingera elatior* (Jack) and early detection of mutation using RAPD markers. *Turk J Biol.* 2013; 37: 716 – 725.
27. Şuğan NA, Popescu A, Mihăescu C, Cristina LS, Marinescu MV. Evaluation of Cytotoxic and Genotoxic Potential of the Fungicide Ridomil in *Allium cepa* L. *Anale Stint. univ. Al. I. Cuza Iasi, II a. Bio Veget.* 2014; 60 (1): 5-12.
28. Al-Anbari AK, Al-Hadeethi, MA, Jawad, MM. Detection of Genetic Relationships among some species belongs to genus *malus* from mid Iraqi regions. *Tikrit J. Pure Sci.* 2017; 22(2): 27-32.
29. Al-Hadeethi MAH, Aljewari H, Jawad MM, Al-Khesragi TO. Genetic Diversity and Relationships among *Verbascum* Species in Iraq by RAPD – PCR Technique. *Glob J Mol Evol Genom.* 2014; 2(2): 62-74.
30. Pinarkara E, Kayis SA, Hakki EE, Sag A (2008). RAPD analysis of seized marijuana (*Cannabis sativa*) in Turkey. *EJB.* 2008; 12(1): 1-13.